

St Louis de Montfort School

BBQ Trailer Hire (for Not for Profit or Charity Groups)

Please fill out the attached form and contact booking coordinator Tony Allday on 9580 7344 to confirm your hire date and to organize payment and pick up/drop off details.

BBQ Trailer Hiring Conditions & Policy

The \$90.00 hiring fee (inclusive of bbq gas cost) is to be paid when making the booking (cash or cheque only). Cheques should be made payable to St Louis de Montfort Mens Committee.

The trailer will be hired clean and with full gas cylinders.

Once the plate has been heated, burners should be turned down so as not to warp the plate.

The BBQ must be cleaned before return, or the hirer will be liable for extra fees. Please re-oil the cooking plate after cleaning and do not fit the cover until the plate has cooled. The gas cylinders will be refilled by us upon the trailers return.

St. Louis de Montfort's School, Aspendale agrees to allow the party named (the hirer) to use the barbecue trailer on the condition that the hirer agrees to use the equipment at their own risk. The hirer also accepts:

- Responsibility for picking the trailer up from and returning it to the nominated location at the agreed times.
- That St. Louis de Montfort's School accepts no liability whatsoever for personal injury or property damage arising out of the operation of the barbecue or the transport of the trailer whilst under the care of the hirer.
- Responsibility for all or any damage or theft of all or any of St Louis de Montfort's equipment whilst in the hirer's care.
- That if using the barbecue to operate a food business under the meaning of Food Safety Legislation current at the time, they are responsible for all necessary arrangements to register the business and to operate in accordance with Food Safety Legislation.

St Louis de Montfort School

BBQ Trailer Hire (for Not for Profit or Charity Groups)

Name of Hiring Organisation/Group: _____

Contact Person: _____

Phone No. _____ Mob. No. _____

Address: _____

Signature of person accepting conditions: _____

Date of Hire: _____

Pick-up Time: _____

Location to collect trailer: _____

Date of Return: _____

Return Time: _____

Location to return trailer: _____

St Louis de Montfort's Contacts:

Tony Allday: 9580 7344

After Hours Contacts: Ph:

..... Ph:

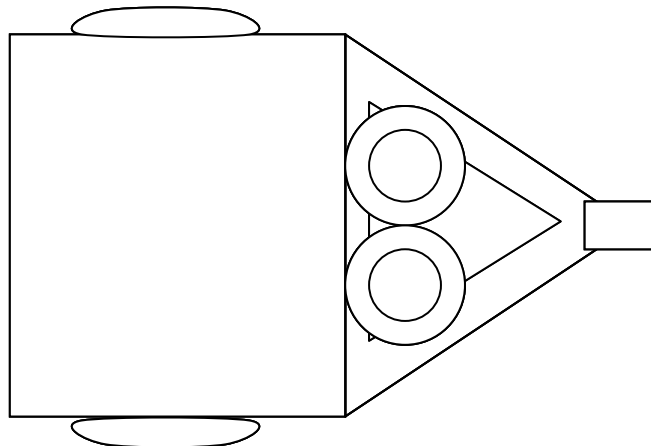

(Highlighted areas were damaged prior to hiring.)